

AD131 LAMP MODULE

This plug-in Lamp Module is a transceiver which is a Z-Wave™ enabled device and is fully compatible with any Z-Wave™ enabled network. Z-Wave™ enabled devices displaying the Z-Wave™ logo can also be used with it regardless of the manufacturer, and ours can also be used in other manufacturer's Z-Wave™ enabled networks. Inclusion of the Lamp Module on other manufacturer's Wireless Controller menu allows remote On/Off control and dimming of lamps connected. Each module is designed to act as a repeater. Repeaters will re-transmit the RF signal to ensure that the signal is received by its intended destination by routing the signal around obstacles and radio dead spots. The plug-in Lamp Module is compatible with our Motion Detectors SP103 and Door/Window Detectors SM103.

Adding to Z-Wave™ Network

In the front casing, there is an On/Off/Dim knob which is used to carry out inclusion, exclusion or association. Put a Z-Wave™ Wireless Controller into inclusion/exclusion mode, press the knob on the Module to complete the inclusion/exclusion process.

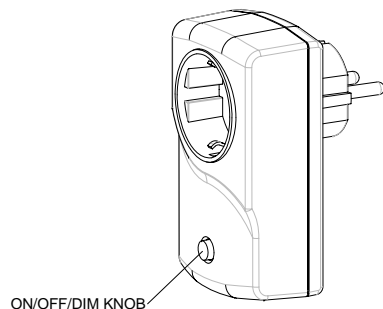

Installation

1. Plug this Lamp Module into a wall outlet near the lamp to be controlled.
2. Plug the lamp into the Lamp Module. Make sure the lamp to be controlled cannot exceed 400 watts.
3. Turn the knob or switch on the lamp to the ON position.
4. To manually turn ON the AD131 Lamp Module, press and release the On/Off/Dim knob. The red indicator LED will turn ON, and the lamp plugged

into the AD131 Lamp Module will also turn ON.

5. To manually turn OFF the AD131 Lamp Module, simply press and release the On/Off/Dim knob. The red indicator LED will turn OFF and the lamp plugged into the Module will also turn OFF.
6. To manually dim the AD131 Lamp Module, press and hold the On/Off/Dim knob until the desired lighting level has been reached.
7. If Motion Detector SP103 or Door/Window Detector SM103 has been removed from the wall by triggering the tamper switch, the Detector (SP103 or SM103) will send an alarm command (**ALARM_REPORT, Alarm Type == 0x01, Alarm Level == 0x11**) to the Module, of which red indicator LED and the lamp plugged into the Module will flash for 10 seconds simultaneously.

Programming

The On/Off/Dim knob allows the user

- Turn on, off or dim the lamp attached
- Include or exclude the Module from the Z-Wave™ system
- Control other Z-Wave™ enabled devices

See the instructions for SP103 Motion Detector or SM103 Door/Window Detector.

Troubleshooting

| Symptom | Cause of Failure | Recommendation |
|--|---|---|
| The Module not working and LED off | 1. The Module is not plugged into the electrical outlet properly 2. The Module is out of order | 1. Check power connections 2. Don't open up the Module and send it for repair. |
| The Module LED illuminating, but cannot control the ON/OFF Switch of the lamp attached | Check if the lamp plugged into the Module has burned out | Replace a new lamp |
| The Module LED illuminating, but the Detector cannot control the Module | 1. Not carry out association 2. Frequency interference | 1. Carry out association 2. Wait for a while to re-try |

Socket Type

Since the socket type for each country in Europe varies, refer to the outline for each socket suited for each country as follows:

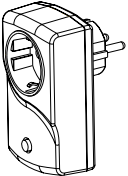
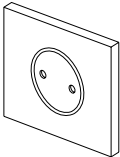
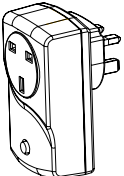
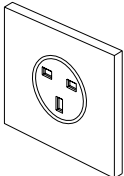
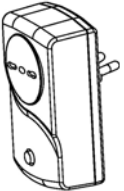
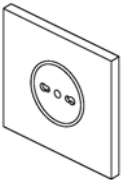
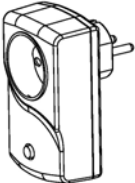
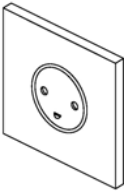
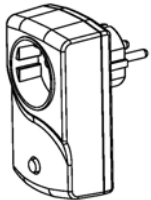
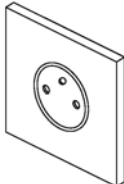
| | | | |
|--|--|---|---|
| AD131-2 | Germany | AD131-3 | U.K. |
|  |  |  |  |
| AD131-4 | Italy | AD131-5 | Denmark |
|  |  |  |  |
| AD131-6 | France | | |
|  |  | | |

Specification

| | |
|-------------------|-----------------------------------|
| Operating Voltage | 230V/50Hz |
| Maximum Load | 400W, for incandescent lamps only |
| Minimum Load | 25W, for incandescent lamps only |
| Range | Minimum 30 m line of sight |
| Frequency Range | 868.42 MHz |

** Specifications are subject to change and improvement without notice.

A501111162R



Warning:

Do not dispose of electrical appliances as unsorted municipal waste, use separate collection facilities.

Contact your local government for information regarding the collection systems available.

If electrical appliances are disposed of in landfills or dumps, hazardous substances can leak into the groundwater and get into the food chain, damaging your health and well-being.

When replacing old appliances with new ones, the retailer is legally obligated to take back your old appliance for disposal at least for free of charge.